

 SPECIALISTE DE LA

RÉPARATION PLASTIQUE

**explast**

Catalogue 2022

Sommaire



1. Les outils.....	4 à 6
2. Agrafes & Soudure plastique.....	7 à 10
3. Les cartouches.....	11 à 13
4. Pistolets, buses et accessoires.....	15 à 16
5. Nettoyage des supports.....	17 à 18
6. Préparation avant peinture.....	19 à 21
7. Les adhésifs - Joints sertis & Double face.....	23 à 26



Direction
Marc CATALÂA
+33 (0)6 88 76 54 81
marc@mix.fr



Commerce & Technique
Marc CATALÂA
+33 (0)6 88 76 54 81
marc@mix.fr

&

Commerce & Technique
Eric HARDOUIN
+33 (0)6 07 17 96 25
eric@mix.fr



Magasin
Jean-Marc LECLERCQ
+33(0)4 66 71 72 82
j.marc@mix.fr



Production et SAV
Julien MOREAU
+33(0)4 66 71 14 47
julien@mix.fr



Production
Nicole FAURE
+33(0)4 66 71 14 47



Comptabilité
Angèle TREUIL
+33(0)4 66 71 14 47
angele@mix.fr



MixPlast© c'est l'histoire d'une « **famille de collaborateurs** »
Forts de 44 années d'expérience et de notre attachement à **l'innovation**,
nous possédons par le biais de notre équipe, de nos partenaires ainsi que de
nos équipements l'ensemble des compétences utiles à **notre métier**.

Développement, formations, technique, commerce.

Toxicologique
MIXPLAST
fds@mix.fr



Commandes
MIXPLAST
commandes@mix.fr

1. Les outils



3662 - PISTOLET POUR AGRAFES ET SOUDURE

3662-CE : KIT COMPLET D'ACCESSOIRES & 3662-L : APPAREIL SEUL



- 🇫🇷 Autonomie, sans fil, MAGIC STAPLER permet de réparer TOUS les thermoplastiques en système agrafes, grilles et apport de matière (baguettes et poudre universelles). Il a une capacité de 2000 agrafes et 35 minutes en mode « fer à souder ». Son ergonomie permet un travail aisé et efficace
- 🇬🇧 Autonomous, cordless, MAGIC STAPLER can repair ALL thermoplastics in a system of staples, wire mesh and material supply (universal rods and powder). It has a capacity of 2000 staples and 35 minutes in welding mode. Its ergonomics allow easy and efficient work
- 🇮🇹 Autonomia, cordless, MAGIC STAPLER può riparare TUTTI i materiali termoplastici in un sistema di graffette, rete inox e aggiunta di materiale (bacchette universali e polvere). Ha una capacità di 2000 graffette e 35 minuti in modo "saldatore". La sua ergonomia consente un lavoro facile ed efficiente

3664 - CLIP'IT - MINI APPAREIL A AGRAFES

- 🇫🇷 CLIP IT est un outil pour la réparation des plastiques dans notre quotidien. Alimenté par 2 piles rechargeables, il a une autonomie d'une cinquantaine d'agrafes
- 🇬🇧 CLIP IT is a tool for repairing plastics, "do it yourself". Powered by 2 rechargeable batteries, it has an autonomy of around 50 staples
- 🇮🇹 CLIP IT è un materiale per riparare la plastica per "fai da te". Alimentato da 2 batterie ricaricabili, ha un'autonomia di circa 50 graffette



Vidéo

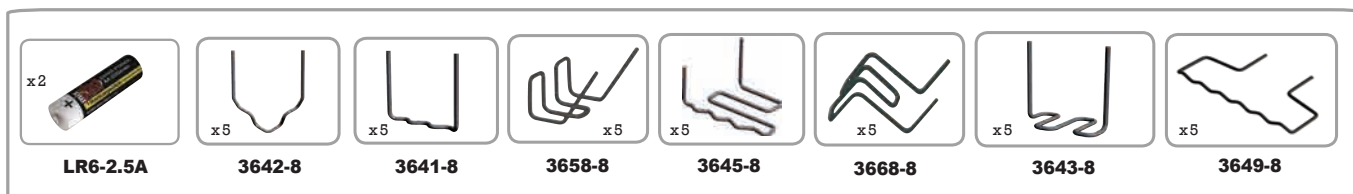

3663 - STARFINISH PISTOLET ANTISTATIQUE

La solution idéale pour le peintre
The ideal solution for the painter
La soluzione ideale per il pittore

Le kit comprend
Kit includes / Il Kit comprende



3663-SUPPORT



A366

(-CE / -UK / -US / -AU)



Vidéo

🇫🇷 STARFINISH élimine l'électricité statique des supports avant peinture. Cela réduit donc considérablement la présence de grains de poussière. Il permet d'effectuer des raccords parfaits et d'éviter les écarts de teintes entre les différents éléments peints. Il rend l'application de la peinture plus facile et plus homogène

🇬🇧 STARFINISH removes static electricity from substrates before painting. This therefore considerably reduces the presence of grains of dust, makes it possible to make perfect blow painting and to avoid color differences between the various painted elements. It makes the application of the paint easier and more even

🇮🇹 STARFINISH rimuove l'elettricità statica dei vari elementi prima della verniciatura. Questo quindi elimina notevolmente la polvere, consente perfetti sfumature e riduce le differenze di colore tra i vari elementi verniciati (parafanghi / paraurti ad esempio). Rende l'applicazione della vernice più facile e più uniforme

3610 - KIT POINÇONS POUR SOUDURE PAR MARQUAGE



Le kit comprend /
Kit includes / Il kit comprende



3610-4M



3610-1F



3610-5F



3610-BOITE



3610-MANCHE



3610-TIGE FILETE

Vidéo



🇫🇷 KIT POINCONS est un système à chaud qui reprend à l'identique les différentes formes thermo soudées à l'intérieur des pare chocs par les robots en usine. Grilles de calendres, supports de radars etc...

🇬🇧 PUNCH-SET is a hot system which uses the different shapes heat-welded inside the bumpers by robots in the factory. Calendar grids, radar supports etc ...

🇮🇹 KIT-MARCHIATURA è un sistema a caldo che utilizza le diverse forme termosaldate all'interno dei paraurti da robot in fabbrica. Griglie calendario, supporti radar ecc ...

2. Agrafes & Soudure plastique

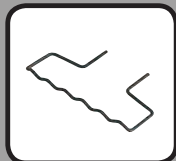

Machine de fabrication agrafes



Contrôle
qualité de la
chaîne de
production

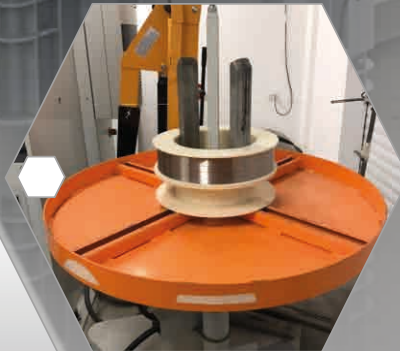

Une cadence
de 24H/24
et 7J/7

2 brevets
France & Europe



inpi
Institut national de la propriété
industrielle

Brevet d'invention

Code de la propriété intellectuelle - Livre III

DÉCISION DE DÉLIVRANCE

Le Directeur général de l'Institut national de la propriété industrielle déclare que le Brevet d'invention n° 13 89964, dont le texte est ci-jointement est octroyé à **MEX Société à responsabilité limitée**.

La délivrance produit son effet pour une période de vingt ans à compter de la date de dépôt de la demande, sous réserve de paiement des annuités.

Mention de la délivrance est faite au Bulletin Officiel de la propriété industrielle n° 1507 du 02.11.15, 1^{er} de publication à 011 744.

AGRAFES BREVETÉES

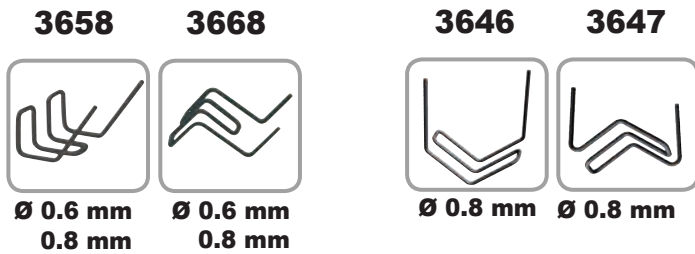
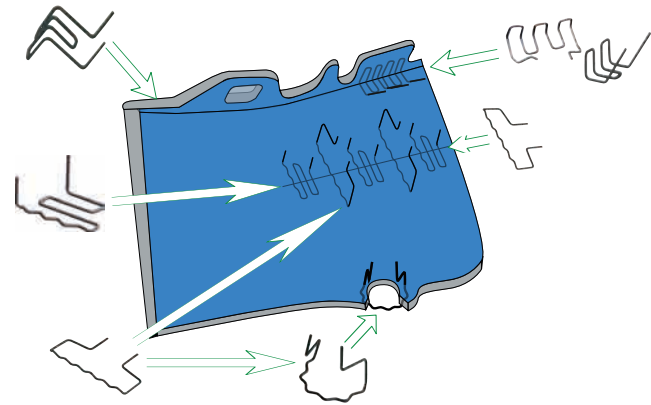
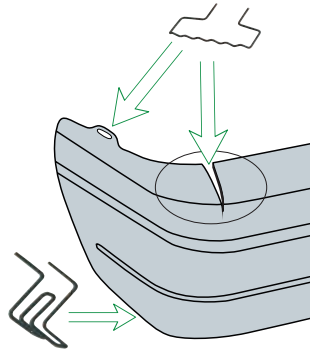
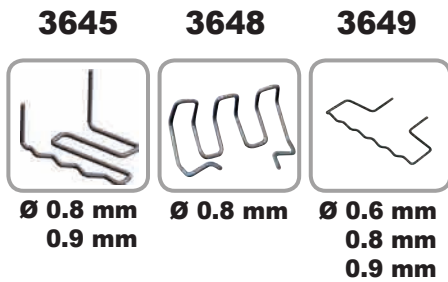

AGRAFES STANDARDS

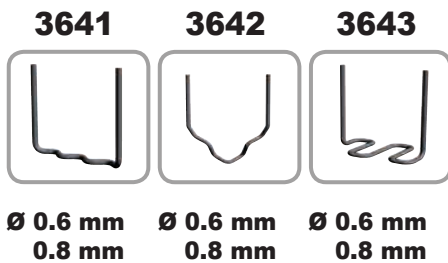

🇮🇹 Agrafes inox disponibles en plusieurs diamètres

🇬🇧 Stainless still staples available in different diameters

🇮🇹 Graffette inox di diametri differenti

364SB - STAPLE BOX - Malette d'agrafes

Le kit comprend /
Kit includes / Il kit comprende

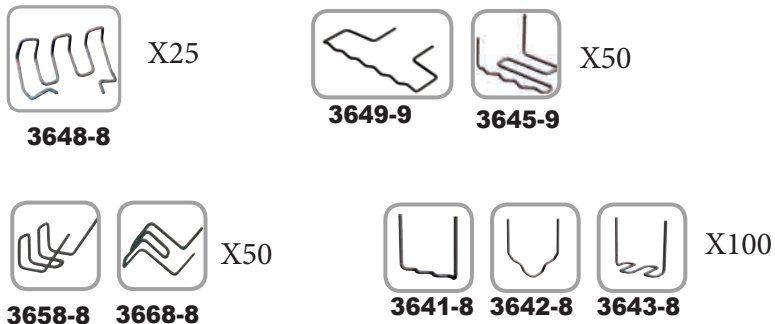

3650 - GRILLE DE RENFORT INOX

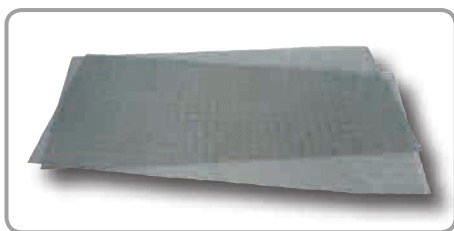

120 x 250 mm

- 🇫🇷 Grille Inox permettant le renfort lors d'une réparation plastique
- 🇬🇧 Wire mesh for reinforcement during plastic repair
- 🇮🇹 Rete inox per rinforzo durante riparazione di plastica

3690 - POUDRE UNIVERSELLE DE BRASAGE



100ML

- 🇫🇷 Poudre universelle de remplissage après une réparation avec la grille 3650 ou les agrafes
- 🇬🇧 Universal plastic powder for refilling after reparation with staples or wire mesh 3650
- 🇮🇹 Polvere plastica universale per il riempimento dopo la riparazione con graffette o rete inox 3650

3692 - BAGUETTE UNIVERSELLE DE BRASAGE

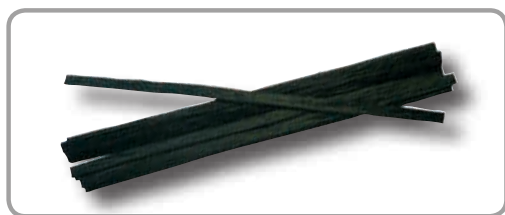

1.5 x 10 x 270

- 🇫🇷 Baguette universelle de remplissage après une réparation avec la grille 3650 ou les agrafes
- 🇬🇧 Universal brazing rod for refilling after reparation with staples or wire mesh 3650
- 🇮🇹 Bacchetta universale di riempimento dopo riparazione con graffette o rete inox 3650

3686 - MASTIC POLYESTER PLASTIQUE VIOLET



780g
A+B

- 🇫🇷 Mastic polyester modifié très flexible
- 🇬🇧 Very flexible Modified mastic polyester
- 🇮🇹 Stucco poliester modificato molto flessibile

3. Les cartouches



Pompe de production cartouches



Le plateau
suiveur
conserve les
produits sous
vide

Remplissage
des cartouches
par l'avant pour
éviter les bulles
d'air

Boîtier de
remplissage
volumétrique

plast
MD15
15sec
FR Collage
rapide
IT Incollaggio
rapido

COLLAGE ET RÉPARATION NOIR 1'30

3608N



200ML

36081N



50ML



1 min30 30 min

Polyuréthane bi-composant semi-rigide noir pour réparation plastique structurale et collages multiples

Black semi-rigid bi-component polyurethane designed for structural plastic repair and multipurpose bonding

Poliuretano bicomponente semi-rigido nero per riparazione plastica e incollaggio multiuso

COLLAGE UNIVERSEL TRANSPARENT 1'30

3607N



200ML

36071N



50ML



1 min 30

Polyuréthane bi-composant semi-rigide transparent pour collages multiples

Transparent semi-rigid bi-component polyurethane designed for multipurpose bonding

Poliuretano bicomponente trasparente semirigido progettato per l'incollaggio multiuso

MD15 - COLLAGE RAPIDE NOIR 15 SEC

MD-15



50ML



15 sec

Polyuréthane bi-composant noir super rapide pour collages ou assemblages multiples

Black bi-component polyurethane for fast bonding or to assemble different substrates together

Poliuretano bicomponente nero rapido per incollare tra loro diversi supporti

FINITION EPOXY GRIS 3'

3689N



200ML

36891N



50ML



3 min 30 min

Epoxy modifié bi-composant semi-rigide pour la finition des plastiques et après 3608

Semi-rigid bi-component modified Epoxy designed for finishing plastic and after 3608

Epossidico bicomponente modificato semi-rigido per la finitura plastica e dopo il 3608

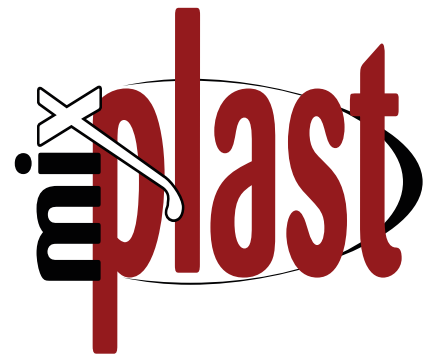

Notre réseau de partenaires en Europe et dans le monde

France dont Guyane, Martinique, Guadeloupe, Réunion

*Australie
Brésil
Canada
Etats-Unis
Grande Bretagne
Irlande*

*Allemagne
Belgique
Chypre
Espagne
Grèce
Italie
Norvège
Pays bas
Portugal
Suisse*

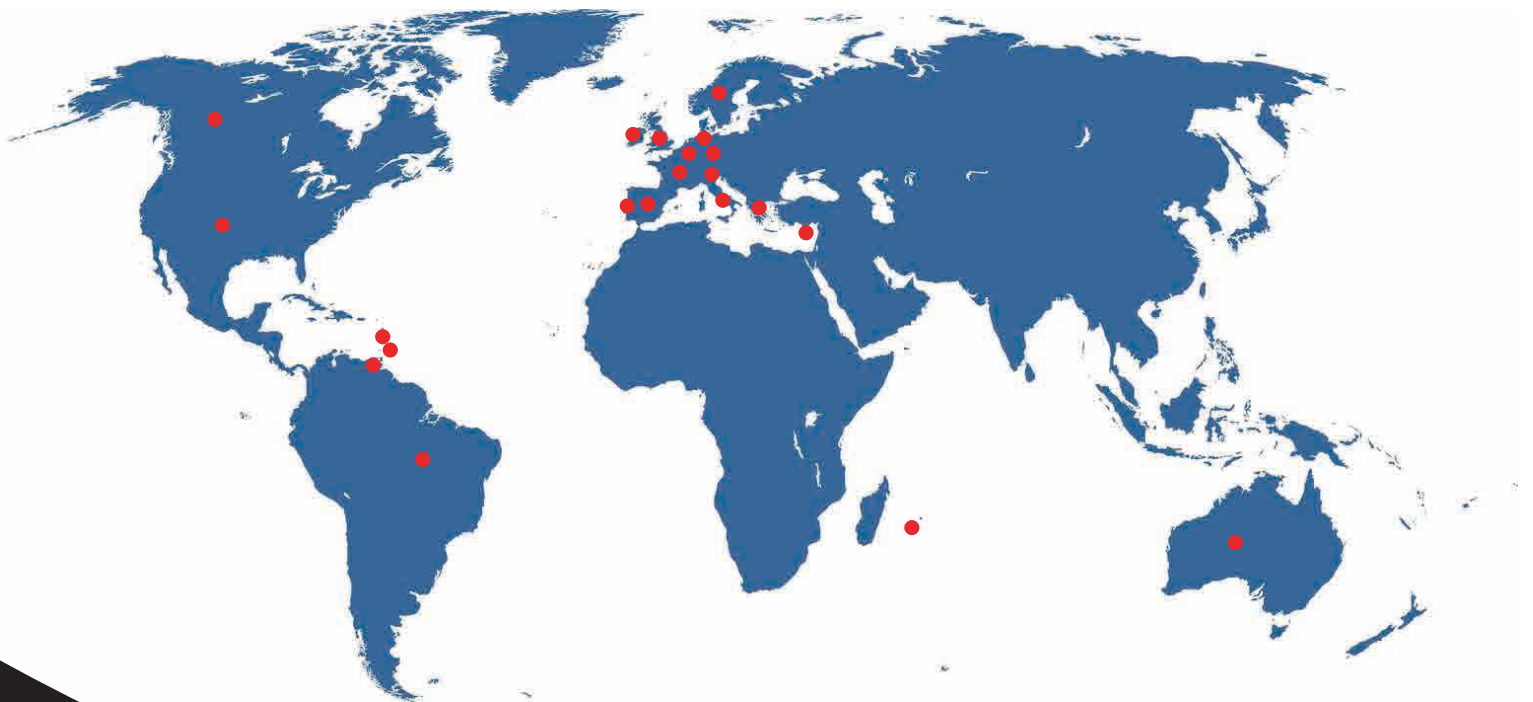

4. Pistolets, buses et accessoires



PISTOLETS POUR CARTOUCHES

  
Pistolet 200ML / 200ML Pistol / Pistola 200ML



  
Pistolet 50ML / 50ML Pistol / Pistola 50ML



BUSES POUR CARTOUCHES

36012N



3601N



36011N





 Buses 200ML
 200ML Mixer
 Beccucci 200ML

 Buses 50ML
 50ML Mixer
 Beccucci 50ML

3653 - PATCH ADHÉSIF THERMOFORMABLE





200 x 100 x 3 mm

-  Patch thermo-formable de réparation adhésif rapide par l'intérieur des cassures, des trous ou tout autre dommage sur les plastiques et composites
-  Patch adhesive thermo-moldable patch for inside on repair tears, holes and many other damages on plastic or composites
-  Patch adesivo termo formabile per riparazioni all'interno di crepe, fori o altri danni sulla plastica e compositi

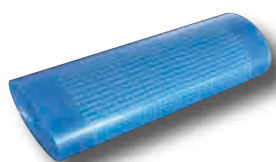
4904 - FILM DE RENFORT AVEC TOILE



L 3.6M

-  Film de renfort tressé pour réparation plastique
-  Reinforcing film roll for plastic repair
-  Film di modellatura con rete

5. Préparation des supports



DÉGRAISSANT A L'EAU



500ML

36021

- 🇫🇷 Dégraissant à l'eau pour salissures, cires, traces de goudron et silicone. Retire les résidus avant, pendant et après la réparation
- 🇬🇧 Water-based degreaser for dirt, waxes, traces of tar and silicone. Removes residue before, during and after repair
- 🇮🇹 Sgrassante a base acqua per sporco, cere, tracce di catrame e silicone. Rimuove i residui prima, durante e dopo la riparazione

DÉGRAISSANT SOLVANTÉ

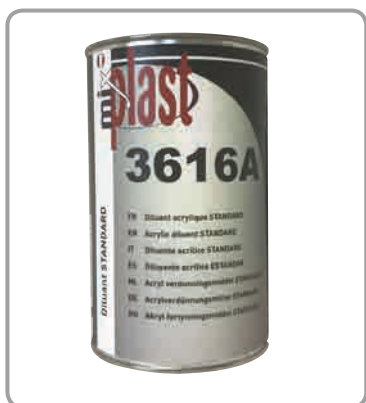

1L

3616A

- 🇫🇷 Permet un dégraissage très efficace des différents éléments
- 🇬🇧 Allows very effective degreasing of the various elements
- 🇮🇹 Consente uno sgrassaggio molto efficace dei vari elementi

3644-D - FRAISE RONDE POUR CHANFREINS



3644-D

- 🇫🇷 Fraise pour chanfreiner une surface avant réparation
Ne brûle pas le plastique
- 🇬🇧 Drill for round-edge before repair
Does not burn plastic
- 🇮🇹 Fresa per smussare l'area prima della riparazione
Non brucia la plastica

6. Préparation avant peinture

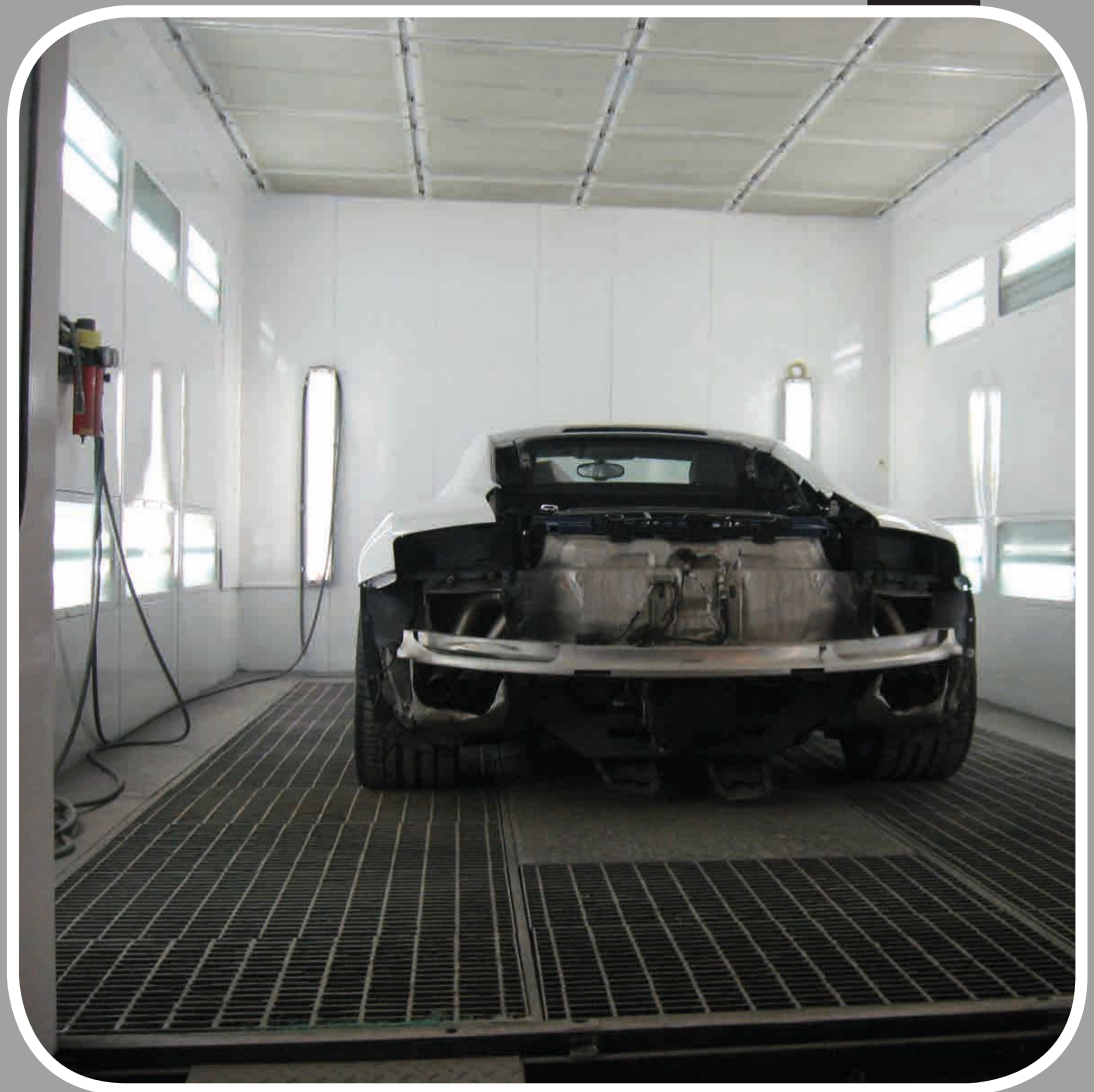

CLEAR BOND PRIMAIRE UNIVERSEL TRANSPARENT



- 🇫🇷 Primaire universel transparent, prêt à l'emploi qui s'utilise en mouillé sur mouillé. Il adhère sur de multiples surfaces telles que : ABS, aluminium, chrome, tôle galvanisée, verre, magnésium, polypropylène, inox, tôle électro-zinguée, cataphorèse, tuiles, céramique, cuivre, carbone...
- 🇬🇧 Universal, transparent, ready-to-use primer for wet-on-wet use. It adheres to multiple surfaces such as: ABS, aluminum, chrome, galvanized sheet, glass, magnesium, polypropylene, stainless steel, electro-galvanized sheet, cataphoresis, tiles, ceramic, copper, carbon ...
- 🇮🇹 Primer universale trasparente, pronto all'uso bagnato su bagnato. Aderisce su buona parte delle superfici come: ABS, alluminio, cromo, lamiera zincata, vetro, magnesio, polipropilene, inox, lamiera elettrozincata, cataforesi, piastrelle, ceramica, cuoio, carbonio ...

BUMPER PLUS PRIMAIRE UNIVERSEL GRIS CLAIR



- 🇫🇷 Primaire universel qui réunit deux fonctions essentielles en carrosserie : l'adhérence parfaite et le mouillé sur mouillé
- 🇬🇧 Universal primer fulfils two essential functions in today's bodyshop: an all-around adhesion promoting primer and wet-on-wet primer-surfacer
- 🇮🇹 Primer universale che riunisce due funzioni essenziali nella carrozzeria di oggi: una perfetta adesione e il bagnato su bagnato

BUMPER PAINT PEINTURE STRUCTURÉE

EXX

FZL

3612



1L

3712



400ML

🇮🇹 Peinture structurée mono composant avec une adhérence directe sur les plastiques et un séchage rapide. La grosseur du grain se fera en fonction de la dilution et de la méthode de pistelage

🇬🇧 One-component structured paint with direct adhesion to plastics and quick drying. The grain size will depend on the dilution and the spraying method

🇮🇹 Vernice strutturata monocomponente testurizzata con adesione diretta su plastica e rapida essiccazione. La dimensione del grano dipenderà dalla diluizione e dal metodo di spruzzatura



3616A - DILUANT - 1L

3410-1 - EQUAMIX HS APPRÊT GARNISSANT PRIMAIRE 2K



2.5L

NOIR

GRIS FONCÉ

GRIS CLAIR

Produit à mélanger avec
To be mixed with
Mescolare con

🇮🇹 EQUAMIX, mélangé à notre additif 3440 et au primaire CLEAR BOND 3670, est un excellent apprêt universel flexible. Adhérence directe sur tous supports, plastiques bruts, tôle...

🇬🇧 EQUAMIX HS, combined with our flexible additive 3440 and adhesion promoter CLEAR BOND 3670, fulfills 3 essential functions, high flexibility, high build thickness and direct adhesion on many substrates such as plastic, aluminium...

🇮🇹 EQUAMIX, con il nostro additivo 3440 e il primer CLEAR BOND 3670, è un eccellente primer universale flessibile. Adesione diretta a tutti elementi, materie plastiche, lamiera, alluminio...



CATALYSEUR
3430 (0.5L)



DILUANT
3616A (1L)

Vous pouvez également ajouter
You can also add
Ma puoi anche aggiungere



FLEXIBILISANT
3440 (0.5L)



ADHÉSION
3670 (1L)





Bologne 2005-2007



Bologne 2009-2011

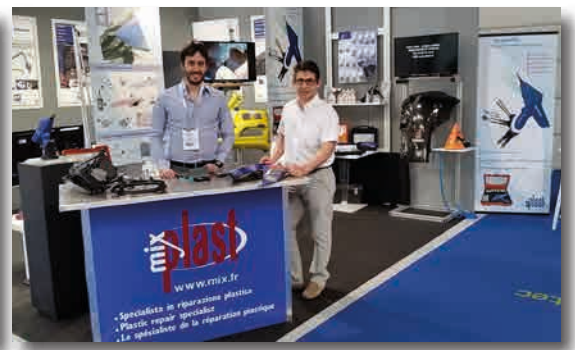

Bologne 2013-2015

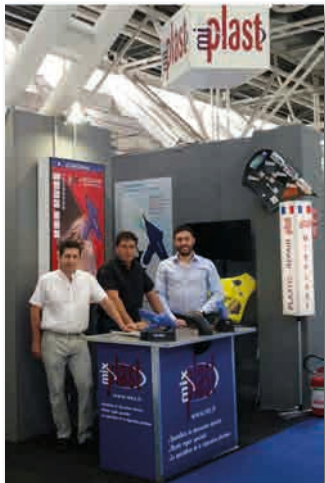

Bologne 2017



Francfort 2008-2010-2012



Francfort 2014-2016-2018

Ces salons nous permettent de renforcer les liens avec nos partenaires mais aussi d'en rencontrer de nouveaux



Végas 2010-2012



Dubaï 2013



Dublin 2016



Paris 2003-2005-2007



Paris 2015-2017-2019

7. Adhésifs

JOINT ADHESIF ADHESIVE TAPE CORDOLO ADESIVO

Toujours parfait - Always perfect - Sempre perfetto

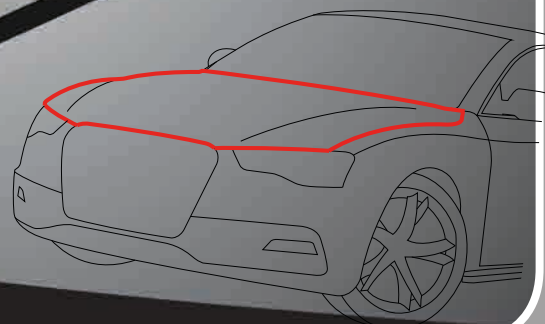
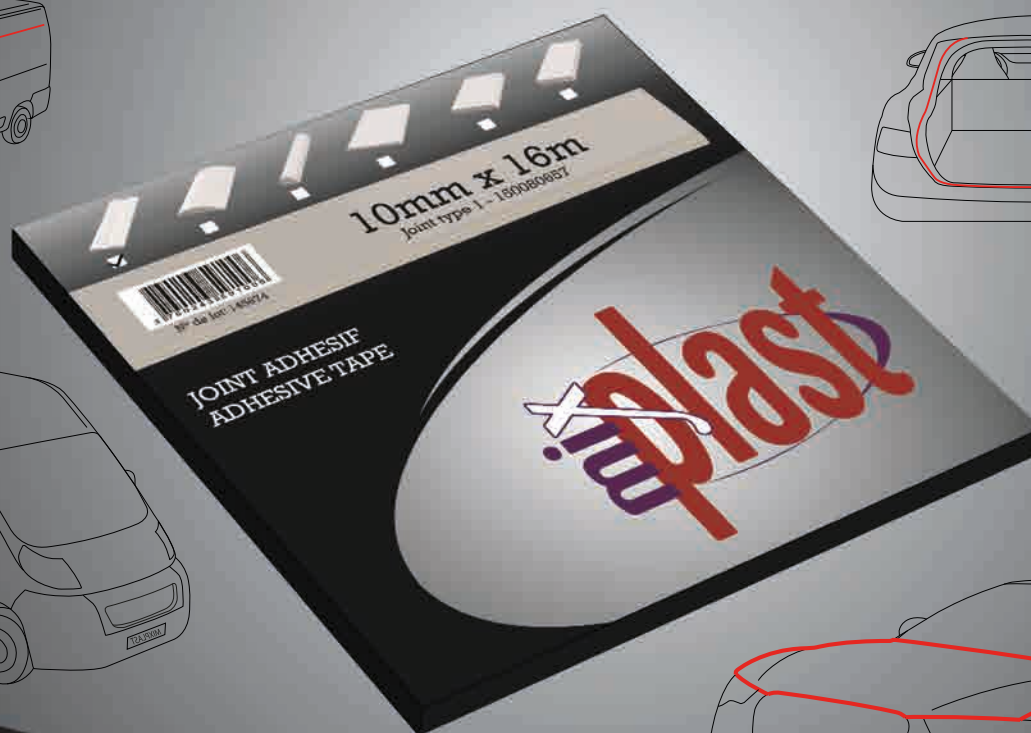
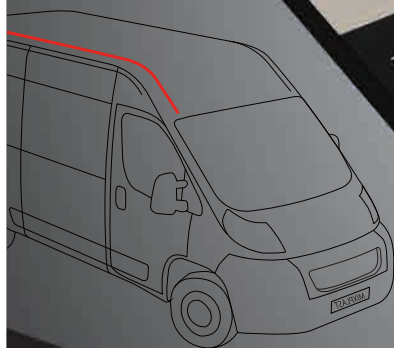
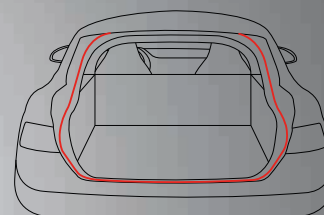
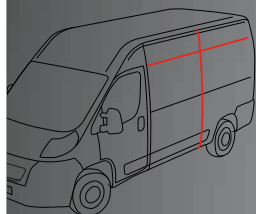
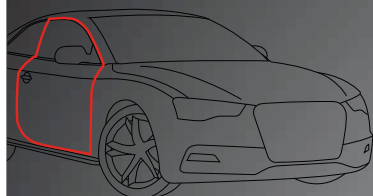
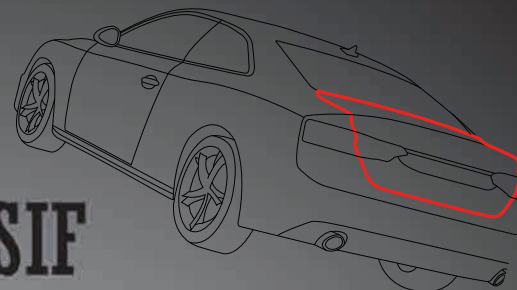

Pour une finition simple et parfaite des joints PU sertis
For a simple and perfect finish of PU sealing tape
Per una finitura semplice e perfetta guarnizioni in PU

🇮🇹 Joints d'étanchéité adhésifs en rouleaux pour reproduire avec précision les joints d'origines présents sur les intérieurs de portières, capots, coffres, passages de roues et pavillons

🇬🇧 Adhesive sealing tape in a roll that perfectly reproduces original sealing shapes commonly present on interior doors skin, hoods, trunks, wheel arches and roofs

🇮🇹 Guarnizioni adesive in rotolo per riprodurre con precisione le giunture originali sulle parti interne di porte, cofani, bauli, passaruota e tetti

35106 ➔ Type 1 - 6 mm x 16M

35108 ➔ Type 1 - 8 mm x 16M

35110 ➔ Type 1 - 10 mm x 16M

35120 ➔ Type 1 - 20 mm x 5M



35206 ➔ Type 2 - 6 mm x 9M

35208 ➔ Type 2 - 8 mm x 9M

35210 ➔ Type 2 - 10 mm x 9M

35212 ➔ Type 2 - 12 mm x 5M



35303 ➔ Type 3 - 3 mm x 6.5M



35412 ➔ Type 4 - 12 mm x 5M

35415 ➔ Type 4 - 15 mm x 5M



35512 ➔ Type 5 - 12 mm x 5M

35515 ➔ Type 5 - 15 mm x 5M



35001/35002 - ROULETTE APPLICATION SERTIS



🇮🇹 Roulette servant à appliquer les différents sertis de la gamme Mixplast. Deux déclinaisons : Escalier/Biseau (35001), Concave/Convexe (35002)

🇬🇧 Roulette used to apply the different joint of the Mixplast range. Two versions: Staircase / Bevel (35001), Concave / Convex (35002)

🇮🇹 Rotella utilizzata per applicare le diverse impostazioni della gamma Mixplast. Due versioni: Scala / Smusso (35001), Concavo / Convesso (35002)

351KIT - KIT JOINTS ADHESIFS SERTIS



🇮🇹 Joints d'étanchéité adhésifs en rouleaux reproduisant à l'identique les joints d'origine présents sur les intérieurs de portières, capots, coffres, ailes arrières, pavillons etc...

🇬🇧 Adhesive seals in rolls identical to the original seals present on the interiors of doors, hoods, trunks, rear fenders, pavilions, etc.

🇮🇹 Guarnizioni adesive in rotoli identiche alle guarnizioni originali presenti sugli interni di porte, cofani, baui, parafanghi posteriori, padiglioni, ecc

Le kit comprend	1 rouleau 6mm x 16 m
/ includes	1 rouleau 8mm x 16 m
/ comprende :	1 rouleau 10mm x 16 m
	1 primaire d'adhérence
	1 roulette pour l'application

352KIT - KIT JOINTS ADHESIFS PANNEAUX



🇮🇹 Joints d'étanchéité adhésifs en rouleaux reproduisant à l'identique les joints d'origine présents sur panneaux latéraux d'utilitaires, ailes arrières, pavillons etc...

🇬🇧 Adhesive seals in rolls identical to the original seals found on utility side panels, rear fenders, pavilions, etc.

🇮🇹 Guarnizioni adesive in rotoli identiche alle guarnizioni originali che si trovano su pannelli laterali di servizio, parafanghi posteriori, padiglioni, ecc.

Le kit comprend	1 rouleau 6mm x 9 m
/ includes	1 rouleau 8mm x 9 m
/ comprende :	1 rouleau 10mm x 9 m
	1 primaire d'adhérence
	1 roulette pour l'application

38... DOUBLE FACE ACRYLIQUE HAUTE PERFORMANCE

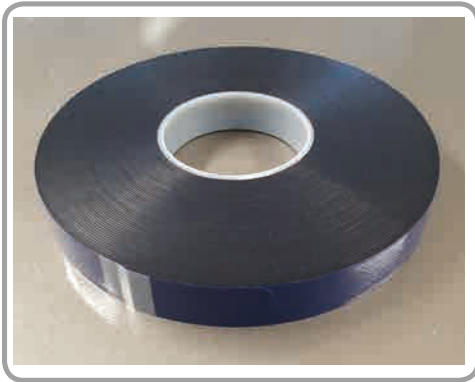

🇮🇹 Ruban en mousse acrylique double face de 1,1 mm d'épaisseur pour un très puissant assemblage structural de garnitures et de pièces intérieures ou extérieures

⊕ 1.1mm thick double-sided acrylic foam tape for very strong structural bonding of interior or exterior trim and parts

🇮🇹 Nastro biadesivo in schiuma acrilica di 1,1 mm di spessore per un incollaggio strutturale molto forte di finiture e parti interne o esterne

3806	➔	1.1 mm x 06 mm x 25M
3809	➔	1.1mm x 09 mm x 25M
3812	➔	1.1mm x 12 mm x 25M
3816	➔	1.1mm x 16 mm x 25M
3819	➔	1.1mm x 19 mm x 25M
3825	➔	1.1mm x 25 mm x 25M

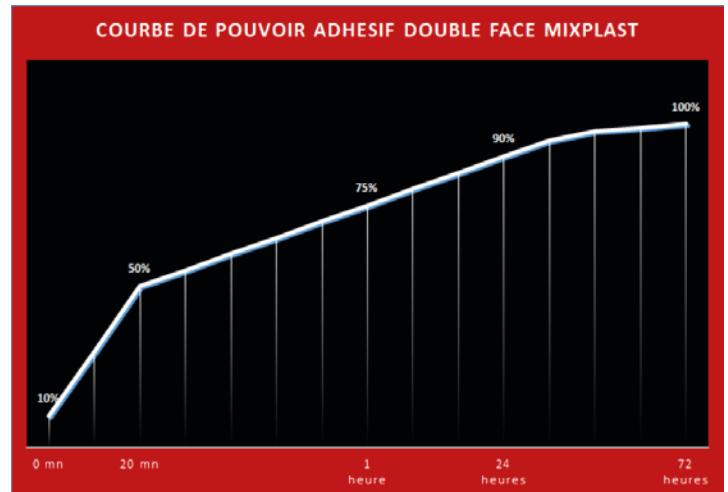

Une aventure humaine

CAO

(Conception assistée par ordinateur)

Travail du design des outils comme le Magic Stapler, le Starfinish, le Kit poinçon ou le Clip'It

PAO

(Publication assistée par ordinateur)

Il est important de fournir les bons documents sans dépendre de prestataires extérieurs

R&D

(Recherche & développement)

Travail sur les aspects mécaniques fonctionnels et économiques de nos innovations



Production et machines

Sur site, nos lignes de montages et nos machines de productions sont organisées pour produire rapidement de petites et moyennes séries

Commerce et technique

Notre équipe, en France et à l'export, est présente sur le terrain afin d'offrir un service et un suivi de qualité sur notre gamme et son utilisation

Brevets

Nos brevets sur les agrafes sont un gage de pérennité et témoignent de notre attachement à l'innovation

Chimistes

Les formules de nos produits sont réalisées en collaboration avec des chimistes

En **hommage à une belle aventure humaine qui rassemble** partenaires et collaborateurs, nous saluons le **travail**, la **créativité** collective, le **professionalisme** et l'**enrichissement** qui en résulte



SPÉCIALISTE DE LA

RÉPARATION PLASTIQUE



Depuis 1978

**Avec un travail bien fait
On obtient toujours un produit de qualité**

ZA de l'avenir
30600 Vestric & Candiac - France
www.mix.fr
Tel: +33(0)4.66.71.14.47
SARL AU CAPITAL DE 500.000€